



INDUSTRIAL & INDOOR LIGHTING



About us



Omnitech Lighting Private Limited (OLT) is an ISO 9001:2015 quality certified LED luminaires manufacturing company specializing in outdoor Flood and Architectural lights that are 100% designed and made in India conforming to the latest Indian and international lighting standards. OLT LED lights have high reliability built into the design through years of R&D and experience.

Omnitech Lighting also undertakes custom design and Manufacturing of project based LED lighting fixtures to suit special applications.

Omnitech Lighting has a modern manufacturing unit located at Greater Noida in Delhi NCR, India. We ensure. All OLT lighting fixtures are tested in-house as well as at NABL accredited labs like UL, Intertek and undergo rigorous testing for extreme temperature and humidity conditions to ensure reliability in all operating conditions.

Photometric design IES files for all OLT luminaires are available to enable customers and architects for design and selection of appropriate type and number of luminaires in any design software like DIALUX, RELUX or AGI 32.



INDUSTRIAL LIGHTING

Bright, uniform and efficient LED lighting for Industrial applications

Industrial Lighting



MODOLED - I



MODOLED - II



STELLA



OMEGA



HYDROLED



Aeroflood
QUBIK-Surface

MODELED-I

IP66 IK08



Energy Label **A++**

LED INDUSTRIAL MEDIUM BAY & HIGH BAY LIGHT

DESIGN FEATURES

- High pressure die cast Aluminium alloy housing
- Polyester powder coating matt black / Graphite grey
- Robust, Sleek design with excellent heat dissipation
- Clear 4mm thick toughened glass / polycarbonate.
- Silicon moulded gaskets for IP66 rating
- Integral / Non integral driver with safety diode to protect the LED module against voltage peaks up to 4KV. P.F. > 0.95.
- All Stainless steel - AISI 304 grade hardware
- Industrial installation with Non Integral bay lights facilitate remote drivers placement at easy to maintain locations. In addition, Group / Individual luminaire controls like Dimming / Day light, Motion sensor enabled.
- **ON REQUEST:** Microwave motion sensor, Dimmable / DALI versions, Daylight sensor, Emergency version through lithium Iron battery pack, Mechanical protection guard.

THERMAL MANAGEMENT

- Generously designed radiator fins in vertical direction to ensure proper air convection

COMPLIANCES - LUMINAIRE

- As Per IS 10322 (Part5/ Sec.5) 2012 & 2015
- IP66, IK08 as per IEC-EN 62262
- On Request: Surface coating resistant to Salt spray tests pursuant to Standard UNI EN ISO 9227.

LEDs

- Power LEDs with high efficacy (>150 lm/W), 4000 / 5700K, with Luminous flux maintenance of 70% (L70 B20) at 50,000 Hrs..
- Low junction thermal resistance for long life and low lumen depreciation
- High colour rendering : CRI - 70/80/90

ELECTRICAL SYSTEM•

- Outdoor rated >90% efficiency constant current drivers with over voltage (440V AC)/Undervoltage, Short circuit & open circuit protection 4KV / 5KV / 6KV inbuilt surge protection
- Optional 10KV / 20 KV external SPD
- Low current harmonics : THD < 10%
- Low flicker : <3%
- Ambient temperature range : -30°C to +50°C

OPTICAL SYSTEM

- Variety of photometric beam options for - Industrial Bays, Aisle Lighting , Double Asymmetric lighting for Vertical storage racks.
- Structured on high performance optical grade lenses in PMMA / PC
- Photometric design data for all optics available



DLT

MODOLED-I

IP66 IK08

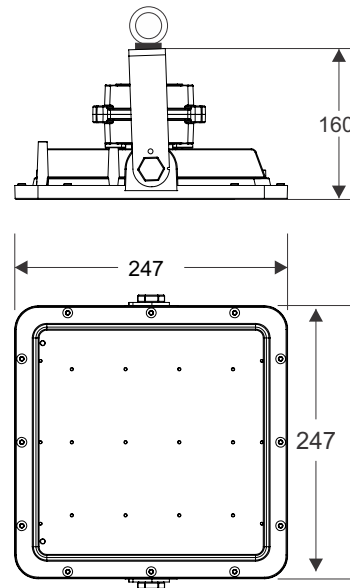

Technical Parameters

- Input AC Voltage : 100V – 280V AC, 50-60 Hz
- Frequency : 50 / 60 Hz
- Luminous Efficacy : 120 Lumens/Watt
- CCT (K) : 5700K / 4000K / 3000K
- Optics : 10° / 15° / 24° / 38° / 60° / 90° / Elliptical Beam / Double Asymmetric / 20°x 90° Elliptical

Technical Specifications

SERIES	ITEM CODE	SYSTEM WATTAGE	INPUT CURRENT	DELIVERED LUMENS	LIGHT BEAM	THD	PF	SURGE PROTECTION	CCT	CRI
MODOLED-I	OLIL-0075-757-60-00	75	0.325	9000	Symm 60°	<10%	0.95	4 KV	5700K	70
MODOLED-I	OLIM-0100-757-60-00	100	0.436	12000	Symm 60°	<10%	0.95	4 KV	5700K	70
MODOLED-I	OLIM-0135-757-60-00	135	0.592	16200	Symm 60°	<10%	0.95	4 KV	5700K	70
MODOLED-I	OLIM-0150-757-20x90	150	0.655	18000	20°x90°	<10%	0.95	4 KV	5700K	70
MODOLED-I	OLIM-0150-757-25-00	150	0.655	18000	Symm 25°	<10%	0.95	4 KV	5700K	70
MODOLED-I	OLIM-0150-757-60-00	150	0.655	18000	Symm 60°	<10%	0.95	4 KV	5700K	70
MODOLED-I	OLIH-0200-757-20x90	200	0.857	24000	20°x90°	<10%	0.95	4 KV	5700K	70
MODOLED-I	OLIH-0200-757-FN-00	200	0.875	24000	AsymFN	<10%	0.95	4 KV	5700K	70
MODOLED-I	OLIH-0200-757-25-00	200	0.875	24000	Symm 25°	<10%	0.95	4 KV	5700K	70
MODOLED-I	OLIH-0200-757-60-00	200	0.875	24000	Symm 60°	<10%	0.95	4 KV	5700K	70

25° - 33° Medium

50° - 60° Wide

24° x 90° Bi Symmetric

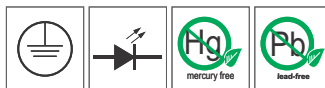
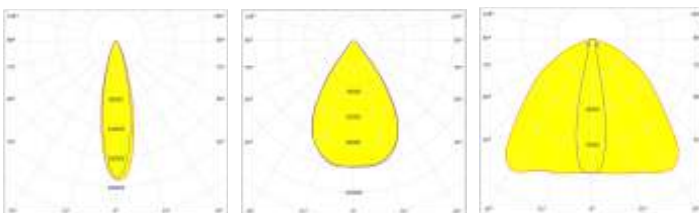

MODELED-II

IP66 IK08



Energy Label **A++**

LED INDUSTRIAL Highbay Light

DESIGN FEATURES

- High pressure die cast Aluminium alloy housing
- Polyester powder coating matt black / Graphite grey
- Robust, Sleek design with excellent heat dissipation
- Clear 4mm thick toughened glass / polycarbonate.
- Silicon moulded gaskets for IP66 rating
- Integral / Non integral driver with safety diode to protect the LED module against voltage peaks up to 4KV. P.F. > 0.95.
- All stainless steel - AISI 304 grade hardware
- Industrial installation with Non integral bay lights facilitate remote drivers placement at easy to maintain locations. In addition, Group / Individual luminaire controls like Dimming / Day light, Motion sensor enabled.
- **ON REQUEST:** Microwave motion sensor, Dimmable / DALI versions, Daylight sensor, Emergency version through lithium Iron battery pack, Mechanical protection guard.

THERMAL MANAGEMENT

- Generously designed radiator fins in vertical direction to ensure proper Air convection

COMPLIANCES - LUMINAIRE

- As Per IS 10322 (Part5/ Sec.5) 2012 & 2015
- IP66, IK08 as per IEC-EN 62262
- **ON REQUEST:** Surface coating resistant to Salt spray tests pursuant to Standard UNI EN ISO 9227.

LEDs

- Power LEDs with high efficacy(>150 lm/W), 4000 / 5700K, with Luminous flux maintenance of 70% (L70 B20) at 50,000 Hrs..
- Low junction thermal resistance for long life and low lumen depreciation
- High colour rendering : CRI - 70/80/90

ELECTRICAL SYSTEM•

- Outdoor rated >90% efficiency constant current drivers with over voltage (440V AC)/Undervoltage, Short circuit & open circuit protection 4KV / 5KV / 6KV inbuilt surge protection
- Optional 10KV / 20 KV external SPD
- Low current harmonics : THD < 10%
- Low flicker : <3%
- Ambient temperature range : -30°C to +50°C

OPTICAL SYSTEM

- Variety of photometric beam options for - Industrial Bays, Aisle Lighting , Double Asymmetric lighting for Vertical storage racks.
- Structured on high performance optical grade lenses in PMMA / PC
- Photometric design data for all optics available



MODOLED-II

IP66 IK08

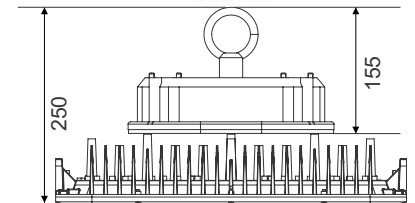
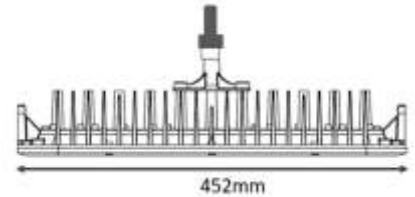
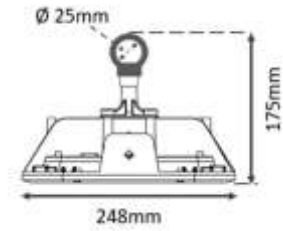

Technical Parameters

Input AC Voltage	: 100V – 280V AC, 50-60 Hz
Frequency	: 50 / 60 Hz
Luminous Efficacy	: 120 Lumens/Watt
CCT (K)	: 5700K / 4000K / 3000K
Optics	: 10° / 15° / 24° / 38° / 60° / 90° / Elliptical Beam / Double Asymmetric / 20°x 90° Elliptical

Technical Specifications

SERIES	ITEM CODE	SYSTEM WATTAGE	INPUT CURRENT	DELIVERED LUMENS	LIGHT BEAM	THD	PF	SURGE PROTECTION	CCT	CRI
MODOLED-II	OLIH-0200-757-60-00	200	0.850	24000	60° x 60°	<10%	0.95	4 KV	5700K	70
MODOLED-II	OLIH-0240-757-60-00	240	1.02	28800	60° x 60°	<10%	0.95	4 KV	5700K	70
MODOLED-II	OLIH-0240-757-25-00	240	1.02	28800	25°	<10%	0.95	4 KV	5700K	70
MODOLED-II	OLIH-0300-757-10-00	300	1.275	36000	10°	<10%	0.95	4 KV	5700K	70
MODOLED-II	OLIH-0300-957-42-00	300	1.275	30900	42°	<10%	0.95	4 KV	5700K	90
MODOLED-II	OLIH-0300-757-60-00	300	1.275	36000	60° x 60°	<10%	0.95	4 KV	5700K	70
MODOLED-II	OLIH-0300-757-FN-00	300	1.275	36000	Asymm FN	<10%	0.95	4 KV	5700K	70
MODOLED-II	OLIH-0350-757-28-00	350	1.495	42000	28°	<10%	0.95	4 KV	5700K	70
MODOLED-II	OLIH-0350-757-60-00	350	1.495	42000	60° x 60°	<10%	0.95	4 KV	5700K	70

10° - 15° Narrow

25° - 33° Medium

50° - 60° Wide

24° x 90° Bi Symmetric

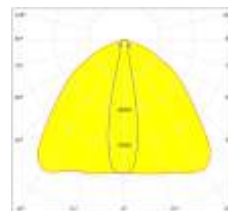
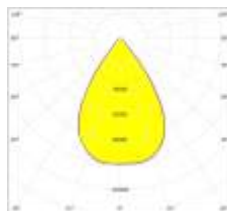
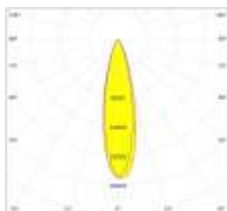
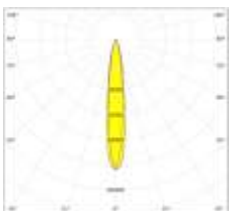

STELLA

IP66 IK08



Energy Label **A++**

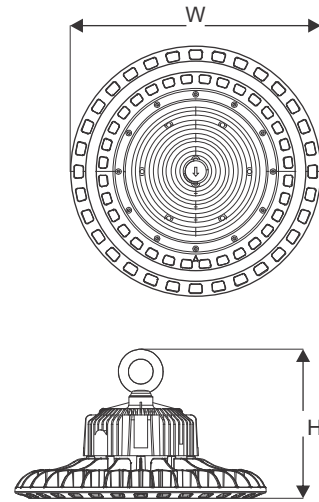

LED INDUSTRIAL MEDIUM BAY & HIGH BAY LIGHT

SPECIFICATION

- High pressure die cast Aluminium alloy housing
- Robust, Sleek design with excellent heat dissipation
- Silicon moulded gaskets for IP66 rating
- All stainless steel - AISI 304 grade hardware
- **LED** : Power LEDs with high efficacy (>150 lm/W), 3000/4000/5700K, with luminous flux maintenance of 70% (L70 B20) at 50,000 Hrs.
- **Lens** : 30°/ 60°/ 90°
- **Diffuser** : Integrated polycarbonate IP66 lens
- **Coating**: Polyester powder coating
- **Driver** : Integral driver with safety diode to protect the LED module against voltage peaks up to 4KV. P.F. > 0.95.
- **Ambient Temperature Zone** : -30 °C to +50°C
- **Input Voltage Range** : 100V – 280V AC, 50-60 Hz



Application image for reference purpose only

Technical Specifications

SERIES	ITEM CODE	SYSTEM WATTAGE	INPUT CURRENT	DELIVERED LUMENS	LIGHT BEAM	THD	PF	SURGE PROTECTION	CCT	CRI	DIMENSION (ØWxH)mm
STELLA-I	OLIM-0100-757-60-00	100	0.438	12000	60°	<10%	0.95	4 KV	5700K	70	Ø282x115
STELLA-II	OLIH-0150-757-60-00	150	0.657	18000	60°	<10%	0.95	4 KV	5700K	70	Ø342x119
STELLA-III	OLIH-0200-757-30-00	200	0.877	24000	30°	<10%	0.95	4 KV	5700K	70	Ø403x128

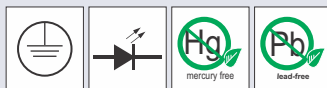
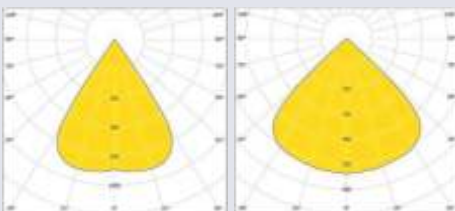

OMEGA

IP66 IK08



Energy Label A++

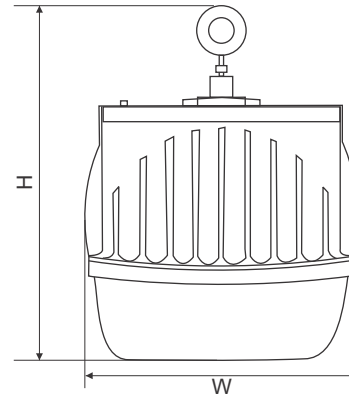

LED INDUSTRIAL WELLGLASS LIGHT

SPECIFICATION

- High pressure die cast Aluminium alloy housing
- Robust, Sleek design with excellent heat dissipation
- Silicon moulded gaskets for IP66 rating
- All Stainless steel - AISI 304 grade hardware
- **LED** : Power LEDs with high efficacy (>150 lm/W), 3000/4000/5700K, with Luminous Flux maintenance of 70% (L70 B20) at 50,000 Hrs.
- **Optics** : 140° Wide
- **Diffuser** : Polycarbonate Clear / Opal
- **Coating**: Polyester powder coating
- **Driver** : Integral driver with safety diode to protect the LED module against voltage peaks up to 4KV. P.F. > 0.95.
- **Ambient Temperature Zone** : -30 °C to +50°C
- **Input Voltage Range** : 100V – 280V AC, 50-60 Hz



Application image for reference purpose only

Technical Specifications

SERIES	ITEM CODE	SYSTEM WATTAGE	INPUT CURRENT	DELIVERED LUMENS	LIGHT BEAM	THD	PF	SURGE PROTECTION	CCT	CRI	DIMENSION (ØWxH)mm
OMEGA	OLWG-0025-757-140-00	25	0.109	2750	140°	<10%	0.95	4 KV	5700K	70	Ø175x250
OMEGA	OLWG-0040-757-140-00	40	0.175	4800	140°	<10%	0.95	4 KV	5700K	70	Ø175x250

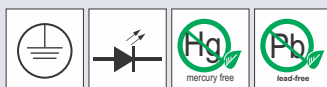
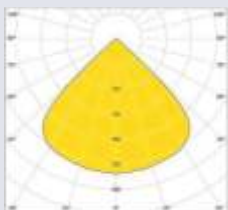

HYDROLED

IP66 IK08



Energy Label **A++**



LED INDUSTRIAL TASK & LOWBAY LIGHT

SPECIFICATION

- **Housing** : Polycarbonate V2 self extinguishing UV resistant
- **LEDs** : Midpower LEDs with high efficacy (>160lm/W), having Luminous Flux maintenance of 70% (L70 B20) at 50,000 Hrs.
- **Mounting** : With Stainless steel clips
- **Diffuser** : Opal polycarbonate V2 self extinguishing UV resistant High transmittance
- **Driver** : Integral driver with safety diode to protect the LED module against voltage peaks up to 4KV. P.F. > 0.95.
- **Ambient Temperature Zone** : -30 °C to +50°C
- **Input Voltage Range** : 100V – 280V AC, 50-60 Hz



Application image for reference purpose only

Technical Specifications

SERIES	ITEM CODE	SYSTEM WATTAGE	INPUT CURRENT	DELIVERED LUMENS	LIGHT BEAM	THD	PF	SURGE PROTECTION	CCT	CRI	DIMENSION (LxWxH)mm
HYDROLED	OLIG-0025-757-DIF-00	25	0.109	2250	DIFF	<10%	0.95	4 KV	5700K	70	590x86x66
HYDROLED	OLIG-0040-757-DIF-00	40	0.175	3600	DIFF	<10%	0.95	4 KV	5700K	70	1180x86x66

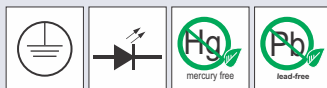
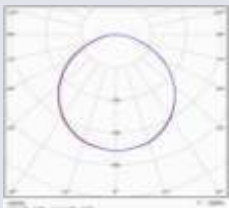

Aeroflood-QUBIK-Surface

IP66 IK08



Energy Label **A++**

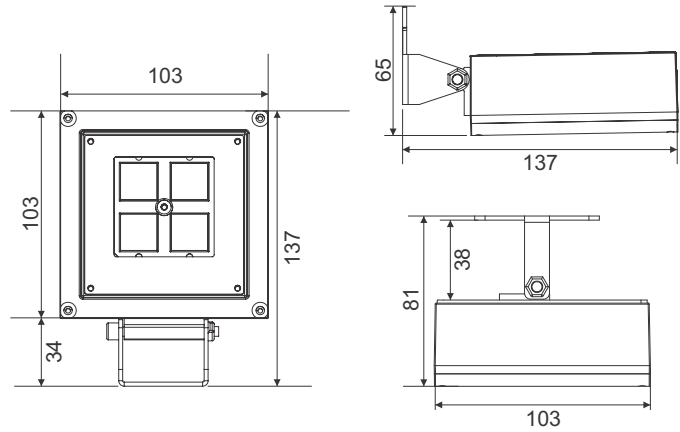

LED INDUSTRIAL TASK & LOWBAY LIGHT

SPECIFICATION

- High Pressure die cast Aluminium alloy housing
 - Robust, Sleek design with excellent heat dissipation
 - Silicon moulded gaskets for IP66 rating
 - All Stainless steel - AISI 304 grade hardware
 - **LED** : Power LEDs with high efficacy (>140 lm/W), Outdoor Illumination grade SMD LEDs, LM80 Certified., 3000/4000/5700K, with Luminous flux maintenance of 70% (L70 B20) at 50,000 Hrs.
 - **Optics** : Symmetric : 60° /90°, Asymmetric : 20°x 90° Oval / FN - Forward Asymmetric 45°
 - **Diffuser** : 3mm thick extra clear toughened glass
 - **Coating**: Polyester powder coating
 - **Driver** : Integral driver with safety diode to protect the LED module against voltage peaks up to 4KV. P.F. > 0.95.
 - **Ambient Temperature Zone** : -30 °C to +50°C
- Input Voltage Range** : 140V – 277V AC, 50-60 Hz



Application image for reference purpose only

Technical Specifications

SERIES	ITEM CODE	SYSTEM WATTAGE	INPUT CURRENT	DELIVERED LUMENS	LIGHT BEAM	THD	PF	SURGE PROTECTION	CCT	CRI
QUBIK-S	OLFL-0018-757-FN-00	18	0.083	1800	Asymm FN	<10%	0.95	4 KV	4000K	70
QUBIK-S	OLFL-0025-957-TF-00	25	0.011	2500	TUN TF	<10%	0.95	4 KV	4000K	70
QUBIK-S	OLFL-0036-757-20x90	36	0.158	3600	20°x90°	<10%	0.95	4 KV	4000K	70

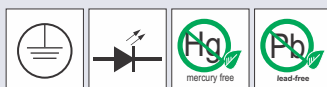
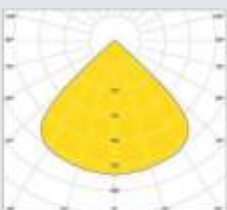







INDOOR COMMERCIAL LIGHTING

Uniform, efficient and
low glare lighting for
offices, and commercial spaces

Indoor Commercial Lighting



COMFORT



SNOW SQUARE
Recess



SNOW SQUARE
Surface



SNOW ROUND
Recess



SNOW ROUND
Surface



COMET - T5
LED Batten

COMFORT

IP66 IK08

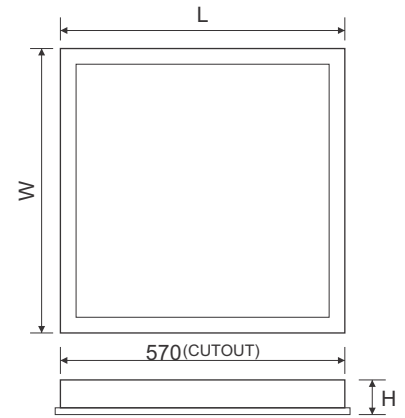

Energy Label **A++**

LED GRID CEILING RECESS MOUNTING TROFFER LIGHT

SPECIFICATION

Housing : CRCA steel powder coated White

Diffuser : Opal PS/PMMA sheet with high transmittance

LEDs : Mid power LEDs with high efficacy (>160lm/W), having Luminous flux maintenance of 70% (L70 B20) at 50,000 Hrs.

Sizes : 2ft x 2ft / 1ft x 1ft / 1ft x 4ft

System Efficacy : > 100 Lm/W. high efficacy 120Lm/w also available on request

CCT /CRI : 3000K / 4000K / 6500K, 80 CRI.

Power Supply : Non Dimmable, P.F. >0.95, THD <10% / 1-10V Dimmable / DALI Dimmable drivers

Ambient Temperature Zone : -30°C to +45°C

Input Voltage Range : 100V – 280V AC, 50-60 Hz



Application image for reference purpose only

Technical Specifications

SERIES	ITEM CODE	SYSTEM WATTAGE	INPUT CURRENT	DELIVERED LUMENS	THD	PF	SURGE PROTECTION	CCT	CRI	DIMENSION (LxWxH)mm
COMFORT	OLCR0020-865-00	20	0.087	2000	<10%	0.95	2 KV	6500K	80	295 x 295 x 70
COMFORT	OLCR0040-865-00	40	0.175	4000	<10%	0.95	2 KV	6500K	80	595 x 595 x 70
COMFORT	OLCR0040-865-00Z	40	0.175	4000	<10%	0.95	2 KV	6500K	80	1195 x 295 x 70

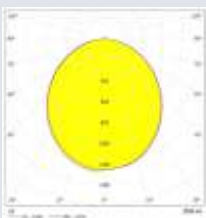

SNOW SQUARE-Recess

IP66 IK08

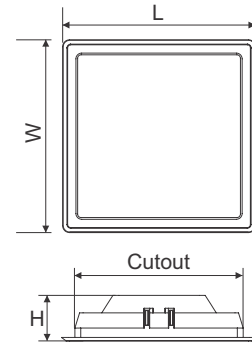

INDOOR
COMMERCIAL LIGHTING

Energy Label **A++**

Dimensions	3W	6W	9W	12W	15W	18W
Outer (LxWxH)	83x83x36	117x117x36	117x117x36	167x167x36	167x167x36	220x220x36
Cut out	63x63	97x97	97x97	147x147	147x147	200x200

LED FALSE CEILING RECESS MOUNTING DOWNLIGHTER

SPECIFICATION

Housing : Engineering plastic white

Diffuser : Opal poly styrene / PMMA sheet with high transmittance

LEDs : Mid power LEDs with high efficacy (>160lm/W), having luminous flux maintenance of 70% (L70 B20) at 50,000 Hrs.

Sizes : Available in 4 different sizes

System Efficacy : > 100 Lm/W. high efficacy 120Lm/W also available on request

CCT /CRI : 3000K / 4000K / 6500K, 80 CRI.

Power Supply : Non Dimmable, P.F. >0.95, THD <10% / 1-10V Dimmable / DALI Dimmable Drivers

Ambient Temperature Zone : -30°C to +45°C

Input Voltage Range : 100V – 280V AC, 50-60 Hz



Application image for reference purpose only

Technical Specifications

SERIES	ITEM CODE	SYSTEM WATTAGE	INPUT CURRENT	DELIVERED LUMENS	THD	PF	SURGE PROTECTION	CCT	CRI	DIMENSION (LxWxH)mm
SNOW SQ-R	OLDR0003-865- SQ	3	0.022	300	<10%	0.95	2 KV	6500K	80	83x83x36
SNOW SQ-R	OLDR0006-865- SQ	6	0.028	600	<10%	0.95	2 KV	6500K	80	117x117x36
SNOW SQ-R	OLDR0009-865- SQ	9	0.042	900	<10%	0.95	2 KV	6500K	80	117x117x36
SNOW SQ-R	OLDR0012-865- SQ	12	0.055	1200	<10%	0.95	2 KV	6500K	80	167x167x36
SNOW SQ-R	OLDR0015-865- SQ	15	0.069	1500	<10%	0.95	2 KV	6500K	80	167x167x36
SNOW SQ-R	OLDR0018-865- SQ	18	0.083	1800	<10%	0.95	2 KV	6500K	80	220x220x36

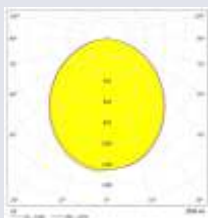

SNOW SQUARE-Surface

IP66 IK08

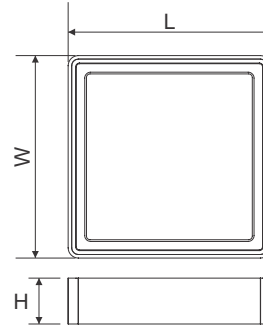

Energy Label **A++**

Dimensions	3W	6W	9W	12W	15W	18W
Outer (LxWxH)	87x87x36	120x120x36	120x120x36	172x172x36	172x172x36	225x225x36

LED CEILING SURFACE MOUNTING DOWNLIGHTER

SPECIFICATION

Housing : Engineering plastic white

Diffuser : Opal poly styrene / PMMA Sheet with high transmittance

LEDs : Mid power LEDs with high efficacy (>160lm/W), having luminous flux maintenance of 70% (L70 B20) at 50,000 Hrs.

Sizes : Available in 4 different sizes

System Efficacy : > 100 Lm/W. High Efficacy 120Lm/W also available on request

CCT /CRI : 3000K / 4000K / 6500K, 80 CRI.

Power Supply : Non Dimmable, P.F. >0.95, THD <10% / 1-10V Dimmable / DALI Dimmable Drivers

Ambient Temperature Zone : -30°C to +45°C

Input Voltage Range : 100V – 280V AC, 50-60 Hz



Application image for reference purpose only

Technical Specifications

SERIES	ITEM CODE	SYSTEM WATTAGE	INPUT CURRENT	DELIVERED LUMENS	THD	PF	SURGE PROTECTION	CCT	CRI	DIMENSION (LxWxH)mm
SNOW SQ-S	OLDS0003-765-SQ	3	0.022	300	<10%	0.95	2 KV	6500K	80	87x87x36
SNOW SQ-S	OLDS0006-765-SQ	6	0.028	600	<10%	0.95	2 KV	6500K	80	120x120x36
SNOW SQ-S	OLDS0009-765-SQ	9	0.042	900	<10%	0.95	2 KV	6500K	80	120x120x36
SNOW SQ-S	OLDS0012-765-SQ	12	0.055	1200	<10%	0.95	2 KV	6500K	80	172x172x36
SNOW SQ-S	OLDS0015-765-SQ	15	0.069	1500	<10%	0.95	2 KV	6500K	80	172x172x36
SNOW SQ-S	OLDS0018-765-SQ	18	0.083	1800	<10%	0.95	2 KV	6500K	80	225x225x36

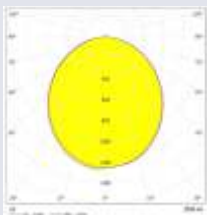

SNOW ROUND-Recess

IP66 IK08

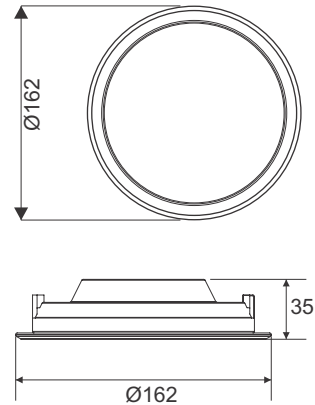

INDOOR
COMMERCIAL LIGHTING

Energy Label **A++**

Dimensions	3W	6W	9W	12W	15W	18W
Outer (ØxH)	Ø83x35	Ø113x35	Ø113x35	Ø162x35	Ø162x35	Ø217x35
Cut out	Ø64	Ø96	Ø96	Ø145	Ø145	Ø198

LED FALSE CEILING RECESS MOUNTING DOWNLIGHTER

SPECIFICATION

Housing : Engineering plastic white

Diffuser : Opal poly styrene / PMMA sheet with high transmittance

LEDs : Mid power LEDs with high efficacy (>160lm/W), having luminous flux maintenance of 70% (L70 B20) at 50,000 Hrs.

Sizes : Available in 4 different sizes

System Efficacy : > 100 Lm/W. High Efficacy 120Lm/W also available on request

CCT /CRI : 3000K / 4000K / 6500K, 80 CRI.

Power Supply : Non Dimmable, P.F. >0.95, THD <10% / 1-10V Dimmable / DALI Dimmable Drivers

Ambient Temperature Zone : -30°C to +45°C

Input Voltage Range : 100V – 280V AC, 50-60 Hz



Application image for reference purpose only

Technical Specifications

SERIES	ITEM CODE	SYSTEM WATTAGE	INPUT CURRENT	DELIVERED LUMENS	THD	PF	SURGE PROTECTION	CCT	CRI	DIMENSION (LxWxH)mm
SNOW RD-R	OLDR0003-765-RD	3	0.022	300	<10%	0.95	2 KV	6500K	80	Ø83x35
SNOW RD-R	OLDR0006-765-RD	6	0.028	600	<10%	0.95	2 KV	6500K	80	Ø113x35
SNOW RD-R	OLDR0009-765-RD	9	0.042	900	<10%	0.95	2 KV	6500K	80	Ø113x35
SNOW RD-R	OLDR0012-765-RD	12	0.055	1200	<10%	0.95	2 KV	6500K	80	Ø162x35
SNOW RD-R	OLDR0015-765-RD	15	0.069	1500	<10%	0.95	2 KV	6500K	80	Ø162x35
SNOW RD-R	OLDR0018-765-RD	18	0.083	1800	<10%	0.95	2 KV	6500K	80	Ø217x35

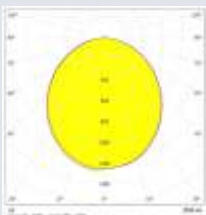

SNOW ROUND-Surface

IP66 IK08

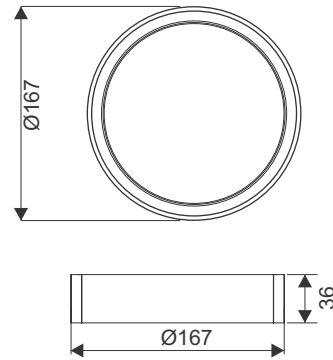

Energy Label **A++**

Dimensions	3W	6W	9W	12W	15W	18W
Outer (ØxH)	Ø88x36	Ø118x36	Ø118x36	Ø167x36	Ø167x36	Ø222x36

LED CEILING SURFACE MOUNTING DOWNLIGHTER

SPECIFICATION

Housing : Engineering plastic white

Diffuser : Opal poly styrene / PMMA sheet with high transmittance

LEDs : Mid power LEDs with high efficacy (>160lm/W), having luminous flux maintenance of 70% (L70 B20) at 50,000 Hrs.

Sizes : Available in 4 different sizes

System Efficacy : > 100 Lm/W. high efficacy 120Lm/W also available on request

CCT /CRI : 3000K / 4000K / 6500K, 80 CRI.

Power Supply : Non Dimmable, P.F. >0.95, THD <10% / 1-10V Dimmable / DALI Dimmable Drivers

Ambient Temperature Zone : -30°C to +45°C

Input Voltage Range : 100V – 280V AC, 50-60 Hz



Application image for reference purpose only

Technical Specifications

SERIES	ITEM CODE	SYSTEM WATTAGE	INPUT CURRENT	DELIVERED LUMENS	THD	PF	SURGE PROTECTION	CCT	CRI	DIMENSION (LxWxH)mm
SNOW RD-S	OLDS0003-765-RD	3	0.022	300	<10%	0.95	2 KV	6500K	80	Ø88x36
SNOW RD-S	OLDS0006-765-RD	6	0.028	600	<10%	0.95	2 KV	6500K	80	Ø118x36
SNOW RD-S	OLDS0009-765-RD	9	0.042	900	<10%	0.95	2 KV	6500K	80	Ø118x36
SNOW RD-S	OLDS0012-765-RD	12	0.055	1200	<10%	0.95	2 KV	6500K	80	Ø167x36
SNOW RD-S	OLDS0015-765-RD	15	0.069	1500	<10%	0.95	2 KV	6500K	80	Ø167x36
SNOW RD-S	OLDS0018-765-RD	18	0.083	1800	<10%	0.95	2 KV	6500K	80	Ø222x36

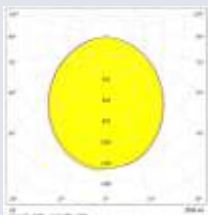

COMET-T5 LED Batten

IP66 IK08

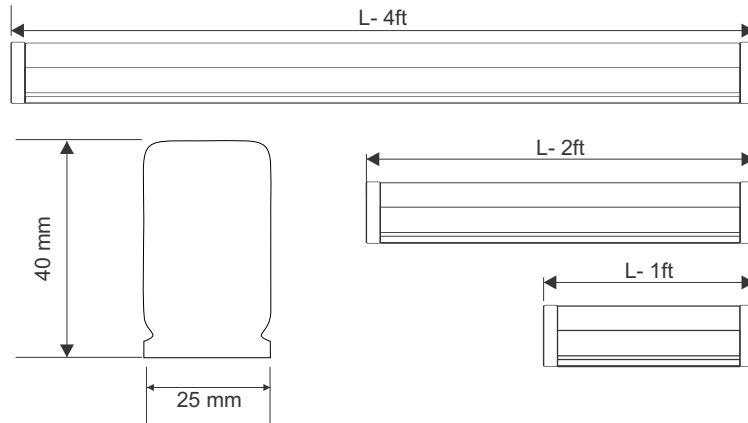
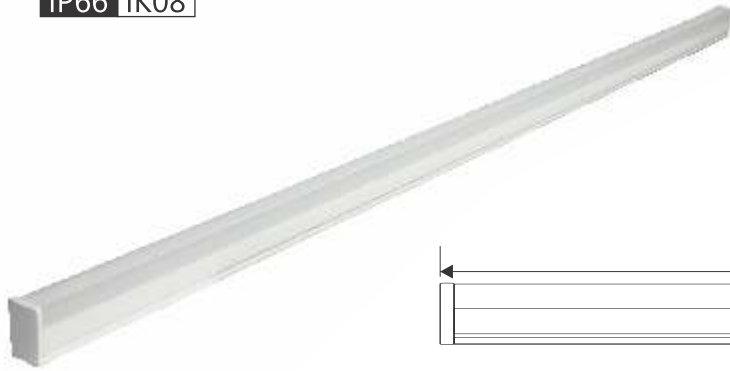

INDOOR
COMMERCIAL LIGHTING

Energy Label **A++**

LED WALL/ CEILING MOUNTING SLIM BATTEN LIGHT

SPECIFICATION

Housing : Engineering plastic white

Diffuser : Opal poly styrene / PMMA sheet with high transmittance

LEDs : Mid power LEDs with high efficacy (>160lm/W), having luminous flux maintenance of 70% (L70 B20) at 50,000 Hrs.

Sizes : Available in 3 different sizes

System Efficacy : > 100 Lm/W. high efficacy 120Lm/W also available on request

CCT /CRI : 3000K / 4000K / 6500K, 80 CRI.

Power Supply : Non Dimmable, P.F. >0.95, THD <10% / 1-10V Dimmable / DALI Dimmable Drivers

Ambient Temperature Zone : -30°C to +45°C

Input Voltage Range : 100V – 280V AC, 50-60 Hz



Application image for reference purpose only

Technical Specifications

SERIES	ITEM CODE	SYSTEM WATTAGE	INPUT CURRENT	DELIVERED LUMENS	THD	PF	SURGE PROTECTION	CCT	CRI	DIMENSION (LxWxH)mm
COMET BATTEN	OLCS0005-865-00	5	0.035	500	<10%	0.95	2 KV	6500K	80	295 x 25 x 40
COMET BATTEN	OLCS0009-865-00	9	0.042	900	<10%	0.95	2 KV	6500K	80	590 x 25 x 40
COMET BATTEN	OLCS0020-865-00	20	0.092	2000	<10%	0.95	2 KV	6500K	80	1180 x 25 x 40

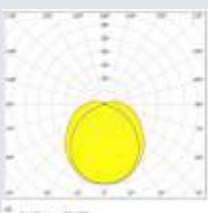

RECOMMENDED ILLUMINATION

As per IS 3646 (Part 1) : 1992

1 ELECTRICITY GENERATION, TRANSMISSION AND DISTRIBUTION

Type of Interior or Activity	Average Service Illuminance in lux	Type of Interior or Activity	Average Service Illuminance in lux
1.1 General Plant			
1.1.1 Turbine Houses (operating floor)	200	2.3.1 Ingot stripping, soaking pits, annealing and heat treatment bays, acid recovery plant pickling and cleaning bays, roughing mills, cold mills, finishing mills, tinning and galvanizing lines, cut up and rewind lines	200
1.1.2 Boiler and turbine house basements	100	2.3.2 General	150
1.1.3 Boiler houses, platforms, areas around burners	100	2.3.3 Control Platforms	300
1.1.4 Switch rooms, meter rooms, oil plant rooms, HV substations (indoor)	150	2.3.4 Wire mills, product finishing, steel inspection and treatment	300
1.1.5 Control rooms	300	2.3.5 Plate/strip inspection	500
1.1.6 Relay and telecommunication rooms	300	2.4 Foundries	
1.1.7 Diesel generator rooms, compressor rooms	150	2.4.1 Automatic plant	
1.1.8 Pump houses, water treatment plant houses	150	2.4.1.1 Without manual operation	50
1.1.9 Battery rooms, chargers, rectifiers	100	2.4.1.2 With occasional manual operation	150
1.1.10 Precipitator chambers, platforms, etc	100	2.4.1.3 With continuous manual operation	200
1.1.11 Cable tunnels and basements, circulating water culverts and screen chambers, storage tanks (indoor), operating areas and filling points at outdoor tanks	50	2.4.1.4 Control room	300
		2.4.1.5 Control platforms	300
1.2 Coal Plant		2.4.2 Non-automatic plants	
1.2.1 Conveyors, gantries, junction towers, unloading hoppers, ash handling plants, settling pits, dust hoppers outlets	100	2.4.2.1 Charging floor, pouring, shaking out, cleaning, grinding fettling	300
1.2.2 Other areas where operators may be in attendance	150	2.4.2.2 Rough moulding, rough core making	300
		2.4.2.3 Fine moulding, fine core making	500
1.3.1 Nuclear Plants		2.4.2.4 Inspection	500
Gas circulation bays, reactor area, boiler platform, reactor charges and discharge face	150	2.5 Forges (Severe vibration is likely to occur)	
		2.5.1 General	300
2 METAL MANUFACTURE		2.5.2 Inspection	500
2.1 Iron Making		3 CERAMICS	
2.1.1 Sinter plant :		3.1 Concrete products	
Plant floor	200	Mixing, casting, cleaning	200
Mixer drum, fan house, screen houses, coolers, transfer stations	150	3.2 Potteries	
2.1.2 Furnaces, cupola:		3.2.1 Grinding, moulding, pressing, cleaning, trimming, glazing, firing	300
General	150	3.2.2 Enameling, colouring	750
Control platforms	300	3.3 Glass Works	
Conveyor galleries, walkways	50	3.3.1 Furnaces rooms, bending, annealing	150
2.2.1 Electric melting shops	200	3.3.2 Mixing rooms, forming, cutting, grinding, Polishing, toughening	300
2.2.2 Basic oxygen steel making plants		3.3.3 Bevelling, decorative cutting, etching, Silvering	500
2.2.2.1 General	150	3.3.4 Inspection	500
2.2.2.2 Converter floor, teeming bay	200	4.1.1 Exterior walkways, platforms, stairs and Ladders	50
2.2.2.3 Control platforms	300	4.1.2 Exterior pump and valve areas	100
2.2.2.4 Scrap bays	150	4.1.3 Pump and compressor houses	150
		4.1.4 Process plant with remote control	50
		4.1.5 Process plant requiring occasional manual intervention	100

RECOMMENDED ILLUMINATION

Type of Interior or Activity	Average Service Illuminance in lux
4.1.6 Permanently occupied work stations in process plant	200
4.1.7 Control rooms for process plant	300
4.2 Pharmaceutical Manufacturer and Fine Chemicals Manufacturer	
4.2.1 Pharmaceutical manufacturer Grinding, granulating, Mixing drying, tableting, sterilizing, washing, preparation of solutions, filling, capping, wrapping, hardening	500
4.2.2 Fine chemical manufacture	
4.2.2.1 Exterior walkways, platforms, stairs and ladders	50
4.2.2.2 Process plant	100
4.2.2.3 Fine chemical finishing	500
4.2.2.4 Inspection	500
4.3 Soap Manufacture	
4.3.1 General area	300
4.3.2 Automatic processes	200
4.3.3 Control panels	300
4.3.4 Machines	300
4.4 Paint Works	
4.4.1 General	300
4.4.2 Automatic processes	200
4.4.3 Control panels	300
4.4.4 Special batch mixing	750
4.4.5 Colour matching	1000
5 MECHANICAL ENGINEERING	
5.1 Structural Steel Fabrication	
5.1.1 General	300
5.1.2 Marking off	500
5.2 Sheet Metal Works	
5.2.1 Pressing, punching shearing, stamping, spinning, folding	500
5.2.2 Bench work, scribing, inspection	750
5.3 Machine and Tool Shops	
5.3.1 Rough bench and machine work	300
5.3.2 Medium bench and machine work	500
5.3.3 Fine bench and machine work	750
5.3.4 Gauge rooms	1000
5.4 Die Sinking Shops	
5.4.1 General	500
5.4.2 Fine work	1500
5.5 Welding and Soldering Shops	
5.5.1 Gas and arc welding, rough spot welding	300
5.5.2 Medium soldering, brazing, spot welding	500
5.5.3 Fine soldering, fine spot welding	1000
5.6 Assembly Shops	
5.6.1 Rough work for example, frame and heavy machine assembly	300
5.6.2 Medium work, for example, engine assembly, vehicle body assembly	500

Type of Interior or Activity	Average Service Illuminance in lux
5.6.3 Fine work, for example, office machinery assembly	750
5.6.4 Very fine work, for example, instrument assembly	1000
5.6.5 Minute work, for example, watch making	1500
5.7 Inspection and Testing Shops	
5.7.1 Coarse work, for example, using go/no go gauges, inspection of large sub-assemblies	500
5.7.2 Medium work, for example, inspection of painted surfaces	750
5.7.3 Fine work, for example, using calibrated scales, inspection of precision mechanisms	1000
5.7.4 Very fine work, for example, inspection of small intricate parts	1500
5.7.5 Minute work, for example, inspection of very small instruments	2000
5.8 Paint Shops and Spray Booths	
5.8.1 Dipping, rough spraying	300
5.8.2 Preparation, ordinary painting, spraying and finishing	500
5.8.3 Fine painting, spraying and finishing	750
5.8.4 Inspection, retouching and matching	1000
5.9 Plating Shops	
5.9.1 Vats and baths	300
5.9.2 Buffing, polishing burnishing	500
5.9.3 Final buffing and polishing	750
6 ELECTRICAL AND ELECTRONIC ENGINEERING	
6.1 Electrical Equipment Manufacture	
6.1.1 Manufacture of cables and insulated wires, winding, varnishing and immersion of coils, assembly of large machines, simple assembly work	300
6.1.2 Medium assembly, for example, telephones, small motors	500
6.1.3 Assembly of precision components, for example, Circuit Boards requiring Manual Insertion of components, inspection and calibration	1000
6.1.4 Assembly of high precision parts	1500
6.2 Electronic Equipment Manufacture	
6.2.1 Printed circuit board	
6.2.1.1 Silk screening	500
6.2.1.2 Hand insertion of components, soldering	750
6.2.1.3 Inspection	1000
6.2.1.4 Assembly of wiring harness, cleat-ing harness, testing and calibration	750
6.2.1.5 Chassis assembly	1000
6.2.2 Inspection and testing:	
6.2.2.1 Soak test	200
6.2.2.2 Safety and functional tests	300

RECOMMENDED ILLUMINATION

Type of Interior or Activity	Average Service Illuminance in lux
7 FOOD , DRINK AND TOBACCO	
Canning, Preserving and Freezing	
7.1.1 Grading and sorting of raw materials	750
7.1.2 Preparation	500
7.1.3 Canned and bottled goods	
7.1.3.1 Retorts	300
7.1.3.2 Automatic processes	200
7.1.3.3 Labeling and packaging	300
7.1.4 Frozen foods	
7.1.4.1 Process area	300
7.1.4.2 Packaging and storage	300
7.2 Bottling, Brewing and Distilling	
7.2.1 Key washing and handling, bottle washing	200
7.2.2 Key inspection	300
7.2.3 Process areas	300
7.2.4 Bottle filling	750
7.3 Edible Oils and Fats Processing	
7.3.1 Refining and blending	300
7.3.2 Production	500
7.4 Bakeries Chocolates and Confectionery	
7.4.1 General	300
7.4.2 Automatic processes	200
7.4.2 Hand decorating, icing, inspection, wrapping and packing	500
7.5 Tobacco Processing	
7.5.1 Material preparation, making and packing	500
7.5.2 Hand Processes	750
8 TEXTILES	
8.1 Fibre Preparation	
8.1.1 Bale breaking, washing	300
8.1.2 Stock dyeing, tinting	300
8.2 Yarn Manufacture	
8.2.1 Spinning, roving, winding, etc	500
8.2.2 Heading (drawing in)	1000
8.3 Fabric Production	
8.3.1 Knitting	500
8.3.2 Weaving	
8.3.2.1 Jute and hemp	300
8.3.2.2 Heavy woolens	500
8.3.2.3 Medium worsteds, fine woolens, cottons	750
8.3.2.4 Fine worsteds, fine linens, Synthetics	1000
8.3.2.5 Mending	1500
8.3.2.6 Inspection	1500
8.4 Fabric Finishing	
8.4.1 Dyeing	300
8.4.2 Calendaring, chemical treatment, etc	500
8.4.3 Inspection	
8.4.3.1 'Grey' cloth	1000
8.4.3.2 Final	1500

Type of Interior or Activity	Average Service Illuminance in lux
8.5 Carpet Manufacture	
8.5.1 Winding, beaming	300
8.5.2 Setting pattern, tufting cropping, trimming, fringing, latexing and latex drying	500
8.5.3 Designing, weaving, mending	750
8.5.4 Inspection	
8.5.4.1 General	1000
8.5.4.2 Piece dyeing	750
9 LEATHER INDUSTRY	
9.1 Leather Manufacture	
9.1.1 Cleaning, tanning and stretching, vats, cutting, fleshing, stuffing	300
9.1.2 Finishing, scarfing	500
9.2 Leather Working	
9.2.1 General	300
9.2.2 Pressing, glazing	500
9.2.3 Cutting, splitting, scarfing, sewing	750
10 CLOTHING AND FOOTWEAR	
10.1 Clothing Manufacture	
10.1.1 Preparation of cloth	300
10.1.2 Cutting	750
10.1.3 Matching	750
10.1.4 Sewing	1000
10.1.5 Pressing	500
10.1.6 Inspection	1500
10.1.7 Hand tailoring	1500
10.2 Hosiery and Knitwear manufacture	
10.2.1 Flat bed knitting machines	500
10.2.2 Circular knitting machines	750
10.2.3 Lockstitch and over locking machine	1000
10.2.4 Linking or running on	1000
10.2.5 Mending, Hand finishing	1500
10.2.6 Inspection	1500
10.3 Glove Manufacture	
10.3.1 Sorting and grading	750
10.3.2 Pressing, Knitting, cutting	500
10.3.3 Sewing	750
10.3.4 Inspection	1500
10.5 Boot and Shoe Manufacture	
10.4.1 Stiffening, braiding, refining, forming, sizing, pounding, ironing	300
10.4.2 Cleaning, flanging, finishing	500
10.4.3 Sewing	750
10.4.4 Inspection	1500
10.5 Boot and Shoe Manufacture	
10.5.1 Sorting and grading	1000
10.5.2 Clicking, closing	1000
10.5.3 Preparatory operations	1000
10.5.4 Cutting tables and pressure	1500
10.5.5 Bottom stock preparation, lasting Bottoming finishing, shoe room	1000

RECOMMENDED ILLUMINATION

Type of Interior or Activity	Average Service Illuminance in lux
10.5.6 Rubber	
10.5.6.1 Washing, compounding, coating, drying, varnishing, vulcanizing, calendering, cutting	300
10.5.6.2 Lining, making and finishing	500
11 TIMBER AND FURNITURE	
11.1 Sawmills	
11.1.1 General	200
11.1.2 Head saw	500
11.1.3 Grading	750
11.2 Woodwork Shops	
11.2.1 Rough sawing, bench work	300
11.2.2 Sizing, planing, sanding, medium machining and bench work	500
11.2.3 Fine bench and machine work, fine sanding, finishing	750
11.3 Furniture Manufacture	
11.3.1 Raw material stores	100
11.3.2 Finished goods stores	150
11.3.3 Wood matching and assembly, rough sawing, cutting	300
11.3.4 Machining, sanding and assembly, polishing	500
11.3.5 Tool rooms	500
11.3.6 Spray booths	
11.3.6.1 Colour finishing	500
11.3.6.2 Clear finishing	300
11.3.7 Cabinet making	
11.3.7.1 Veneer sorting and grading	1000
11.3.7.2 Marquetry, pressing, patching and fitting	500
11.3.7.3 Final inspection	750
11.4 Upholstery Manufacture	
11.4.1 Cloth inspection	1500
11.4.2 Filling, covering	500
11.4.3 Slipping, cutting, sewing	750
11.4.4 Assembly	500
11.4.5 ape edging	1000
12 PAPER AND PRINTING	
12.1 Paper Mills	
12.1.1 Pulp mills, preparation plants	300
12.1.2 Paper and board making	
12.1.2.1 General	300
12.1.2.2 Automatic process	200
12.1.2.3 Inspection, sorting	500
12.1.3 Paper converting processes	
12.1.3.1 General	300
12.1.3.2 Associated printing	500
12.2 Printing Works	
12.2.1 Type foundries	
12.2.1.1 Matrix making, dressing type, hand and machine coating	300
12.2.1.2 Front assembly, sorting	750

Type of Interior or Activity	Average Service Illuminance in lux
12.2.2 Composing rooms	
12.2.2.1 Hand composing, imposition and distribution	750
12.2.2.2 Hot metal keyboard	750
12.2.2.3 Hot metal casting	300
12.2.2.4 Photo composing keyboard or setters	500
12.2.2.5 Paste up	750
12.2.2.6 Illuminated tables - general lighting	300
12.2.2.7 Proof presses	500
12.2.2.8 Proof reading	750
12.2.3 Graphic Reproduction	
12.2.3.1 General	500
12.2.3.2 Precision proofing, retouching, etching	1000
12.2.3.3 Colour reproduction and inspection	1000
12.2.4 Printing machine room	
12.2.4.1 Presses	500
12.2.4.2 Premake ready	500
12.2.4.3 Printed sheet inspection	1000
12.2.5 Binding	
12.2.5.1 Folding, pasting, punching and stitching	500
12.2.5.2 Cutting, assembling, embossing	750
13 PLASTIC AND RUBBER	
13.1 Plastic Products	
13.1.1 Automatic Products	
13.1.1.1 Without manual control	50
13.1.1.2 With occasional manual control	100
13.1.1.3 With continuous manual control	300
13.1.1.4 Control rooms	300
13.1.1.5 Control platforms	300
13.1.2 Non-automatic plant	
13.1.2.1 Mixing, calendaring, extrusion, injection, compression and blow molding, sheet fabrication	300
13.1.2.2 Trimming, cutting, polishing, cementing	500
13.1.2.3 Printing, inspection	1000
13.2 Rubber Products	
13.2.1 Stock preparation - plasticizing, milling	200
13.2.2 Calendaring, fabric preparation, stock cutting	500
13.2.3 Extruding, moulding	500
13.2.4 Inspection	1000
14 DISTRIBUTION AND STORAGE	
14.1 Work Stores	
14.1.1 Unpacking, sorting	200
14.1.2 Large item storage	100
14.1.3 Small item rack storage	300
14.1.4 Issue counter, records, store man's desk	500

RECOMMENDED ILLUMINATION

Type of Interior or Activity	Average Service Illuminance in lux	Type of Interior or Activity	Average Service Illuminance in lux
14.2 Warehouses and Bulk Stores		16.4 Sewage Treatment Works	
14.2.1 Storage of goods where identification requires only limited preparation of detail	100	16.4.1 Walkways	50
14.2.2 Storage of goods where identification requires perception of detail	150	16.4.2 Process areas	100
14.2.3 Automatic high bay rack stores		17.1 Small Shops with Counters	500
14.2.3.1 Gangway	20	17.2 Small Self-Service Shops with Island Displays	500
14.2.3.2 Control station	200	17.3 Super Markets, Hyper-markets	
14.2.3.3 Packing and dispatch	300	17.3.1 General	500
14.2.3.4 Loading bays	150	17.3.2 Checkout	500
14.3 Cold Stores		17.3.3 Showroom for large objects, for example, cars, furniture	500
14.3.1 General	300	17.3.4 Shopping precincts and arcades	150
14.3.2 Breakdown, make-up and dispatch	300	17.4 Fuel Pump Retail Stations	
14.3.3 Loading bays	150	17.4.1 Approach & Exit	50
15 COMMERCE		17.4.2 Under Canopy dispensing Area	300
15.1 Offices		17.4.3 Dispensing Machine Readings Display vertical	200
15.1.1 General offices	300	18 PLACES OF PUBLIC ASSEMBLY	
15.1.2 Deep plan general offices	500	18.1 Public rooms, Village Halls, Worship Halls	
15.1.3 Computer work stations	300	18.2 Concert Halls, Cinemas and Theaters	
15.1.4 Conference rooms, executive offices	300	18.2.1 Foyer	200
15.1.5 Computer and data preparation rooms	300	18.2.2 Booking office	300
15.1.6 Filing rooms	200	18.2.3 Auditorium	100
15.2 Drawing Offices		18.2.4 Dressing rooms	300
15.2.1 General	300	18.2.5 Projection room	150
15.2.2 Drawing boards	500	18.3 Churches	
15.2.3 Print rooms	200	18.3.1 Body of church	150
15.3 Banks and Building Societies		18.3.2 Pulpit, lectern	300
15.3.1 Counter, office area	300	18.3.3 Choir stalls	300
15.3.2 Public area	200	18.3.4 Alter, communion table, chancel	150
16 SERVICES		18.3.5 Vestries	150
16.1 Garages		18.3.6 Organ	300
16.1.1 Interior parking area	30	18.4 Hospitals	
16.1.2 General repairs, servicing, washing, polishing	300	18.4.1 Anesthetic rooms	
16.1.3 Workbench	500	18.4.1.1 General	300
16.1.4 Spray booths	500	18.4.1.2 Local	1000
16.1.5 External apron		18.4.2 Consulting areas	
16.1.5.1 General	50	18.4.2.1 General	300
16.1.5.2 Pump area (retail sales)	300	18.4.2.2 Examination	1000
16.2 Appliance servicing		18.4.3 Corridors	
16.2.1 Workshop		18.4.3.1 General	150
16.2.1.1 General	300	18.4.4 Ward corridors	
16.2.1.2 Workbench	500	18.4.4.1 Day, screened from bays	200
16.2.1.3 Counter	300	18.4.4.2 Day, open to natural light	200
16.2.1.4 Stores	300	18.4.4.3 Morning / evening	150
16.3 Laundries		18.4.4.4 Night	10
16.3.1 Commercial laundries		18.4.5 Cubicles	
16.3.2 Receiving, sorting, washing, drying, ironing Dispatch, dry-cleaning, bulk machine work	300	18.4.5.1 General	300
16.3.3 Head ironing, pressing, mending, spotting, Inspection	500	18.4.5.2 Treatment	1000
16.3.4 Launderettes	300		

RECOMMENDED ILLUMINATION

Type of Interior or Activity	Average Service Illuminance in lux
18.4.6 Examination	
18.4.6.1 General	300
18.4.6.2 Local inspection	1000
18.4.7 Intensive therapy	
18.4.7.1 Bad head	50
18.4.7.2 Circulation between bed ends	100
18.4.7.3 Observation	300
18.4.7.4 Local observation	1000
18.4.7.5 Staff base (day)	300
18.4.7.6 Staff base (night)	30
18.4.8 Laboratories	
18.4.8.1 General	300
18.4.8.2 Examination	500
18.4.9 Nurses' stations	
18.4.9.1 Morning/day/evening	300
18.4.9.2 Night desks	30
18.4.9.3 Night, medical trolleys	100
18.4.10 Operating theaters	
18.4.10.1 General	500
18.4.10.2 Local	50000
18.4.11 Pathology departments	
18.4.11.1 General	300
18.4.11.2 Examination	500
18.4.11.3 Pharmacies	300
18.4.11.4 Reception / enquiry	300
18.4.11.5 Recovery rooms	300
18.4.12 Ward-circulation	
18.4.12.1 Day	100
18.4.12.2 Morning / evening	100
18.4.12.3 Night	
518.4.13 Ward-bed head	
18.4.13.1 Morning / evening	50
18.4.13.2 Reading	150
18.4.14 Night	
18.4.14.1 Adult	1
18.4.14.2 Pediatric	1
18.4.14.3 Psychiatric	5
18.4.14.4 Watch	5
18.4.15 X-Ray areas	
18.4.15.1 General	200
18.4.15.2 Diagnostic	200
18.4.15.3 Operative	300
18.4.15.4 Process dark room	50
18.4.16 Surgeries	
18.4.16.1 General	300
18.4.16.2 Waiting rooms	150
18.4.17 Dental Surgeries	
18.4.17.1 Chair Special lighting	
18.4.17.2 Laboratories	500
18.4.18 Consulting rooms	
18.4.18.1 General	300
18.4.18.2 Desk	500
18.4.18.3 Examination couch	500
18.4.18.4 Ophthalmic wall and near-vision charts	500

Type of Interior or Activity	Average Service Illuminance in lux
18.5 Hotels	
18.5.1 Entrance halls	100
18.5.2 Reception , cashier's and porters' desks	300
18.5.3 Bars, coffee base , dining rooms, grill rooms, restaurants , lounges	200
18.5.4 Cloak rooms, baggage rooms	100
18.5.5 Bed rooms	50
18.5.6 Bathroom	100
18.6 Libraries	
18.6.1 Lending library	
18.6.1.1 General	300
18.6.1.2 Counters	500
18.6.1.3 Bookshelves	150
18.6.1.4 Reading rooms	300
18.6.1.5 Reading tables	300
18.6.2 Catalogues	
18.6.2.1 Card	150
18.6.2.2 Microfiche / Visual display units	150
18.6.3 Reference libraries	
18.6.3.1 Genera	300
18.6.3.2 Counters	500
18.6.3.3 Bookshelves	150
18.6.3.4 Study tables, carrels	500
18.6.3.5 Map room	300
18.6.4 Display and exhibition areas	
18.6.4.1 Exhibits insensitive to light	300
18.6.4.2 Exhibit sensitive to light, for example, pictures, prints rare books in archives	150
18.6.5 Library workrooms	
18.6.5.1 Book repair and binding	500
18.6.5.2 Catalogue and sorting	500
18.6.5.3 Remote book stores	150
18.7 Museums and Art Galleries	
18.7.1 Exhibits insensitive to light	300
18.7.2 Light sensitive exhibits , for example, oil and temper paints, un-dyed leather, bone ivory , wood , etc	150
18.7.3 Extremely light sensitive exhibits, for example ,textiles , water colours, prints and drawings, skins, botanical specimens etc.	50
18.7.4 Conservation studies and workshops	500
18.8 Sports Facilities	
18.8.1 Multi-purpose sports halls	500- 750
18.8.2 Specific Sports : As per respective governing guidelines.	
19 EDUCATION	
19.1 Assembly Halls	
19.1.1 General	300

RECOMMENDED ILLUMINATION

Type of Interior or Activity	Average Service Illuminance in lux
19.2 Teaching Spaces	
General	300
19.3 Lecture Theaters	
19.3.1 General	300
19.3.2 Demonstration benches	500
19.4 Seminar Rooms	500
19.5 Art Rooms	500
19.6 Needlework Rooms	500
19.7 Laboratories	500
19.8 Libraries	300
19.9 Music Rooms	300
19.10 Sports Halls	300
19.11 Workshops	300
20 TRANSPORT	
20.1 Airports	
20.1.1 Ticket counters, checking desks, and information desks	500
20.1.2 Departure lounges, other waiting areas	200
20.1.3 Baggage reclaim	200
20.1.4 Baggage handling	100
20.1.5 Customs and immigration halls	500
20.1.6 Concourse	200
20.2 Railway Stations	
20.2.1 Ticket office	500
20.2.2 Information office	500
20.2.3 Luggage office	
20.2.3.1 General	100
20.2.3.2 Counter	200
20.2.4 Waiting rooms	200
20.2.5 Concourse	200
20.2.6 Time table	200
20.2.7 Ticket barriers	200
20.2.8 Platforms (covered)	50
20.2.9 Platforms (open)	20
20.3 Train Stations	
20.3.1 Ticket offices	500
20.3.2 Information offices	500
20.3.3 Left luggage office	
20.3.3.1 General	100
20.3.3.2 Counter	200
20.3.4 Waiting rooms	200
20.3.5 Concourse	200
20.3.6 Time tables	200
20.3.7 Loading areas	150
21 GENERAL BUILDING AREAS	
21.1 Entrance	
21.1.1 Entrance halls, lobbies , waiting rooms	200
21.1.2 Enquiry desks	500
21.1.3 Gatehouses	200

Type of Interior or Activity	Average Service Illuminance in lux
21.2 Circulation Areas	
21.2.1 Lifts	100
21.2.2 Corridors, passage ways, stairs	100
21.2.3 Escalators, travellers	150
21.3 Medical and first Aid Centres	
21.3.1 Consulting rooms, treatment rooms	500
21.3.2 Rest rooms	150
21.3.3 Medical stores	150
21.4 Staff Rooms	
21.4.1 Changing , locker and cleaners rooms, cloakrooms, lavatories	100
21.4.2 Rest rooms	150
21.5 Staff Restaurants	
21.5.1 Canteens, cafeterias, dining rooms, mess rooms	200
21.5.2 Survey , vegetable preparation , washing-up area	300
21.5.3 Food preparation and cooking	500
21.5.4 Food stores , cellars	150
21.6 Communications	
21.6.1 Switchboard rooms	300
21.6.2 Telephone apparatus rooms	150
21.6.3 Telex rooms , post rooms	500
21.6.4 Reprographic room	300
21.7 Building Services	
21.7.1 Boiler houses	
21.7.1.1 General	100
21.7.1.2 Boiler front	150
21.7.1.3 Boiler control room	300
21.7.1.4 Control rooms	300
21.7.1.5 Mechanical plant room	150
21.7.1.6 Electrical power supply and distribution rooms	150
21.7.1.7 Store rooms	100
21.8 Car Parks	
21.8.1 Covered car parks	
21.8.1.1 Floors	20
21.8.1.2 Ramps and corners	30
21.8.1.3 Entrances and exits	100
21.8.1.4 Control booths	200
21.8.1.5 Outdoor car parks	20





Omnitech Lighting Pvt.Ltd.

Works & Head Office : 524-C, Udyog Kendra Extn.-2,
Ecotech-III, Greater Noida, Gautam Buddha Nagar - 201 308,U.P (India)

Registered Office : 8, Rosedale, Aliganj Road,
Kashipur - 2400 713, Uttarakhand (India)

E-Mail : info@oltindia.com, **Website :** www.oltindia.com

